



**CPL™ 6**  
Loudspeaker System  
扬声器系统

---

Product  
Specifications  
产品说明书



## SPECIFICATIONS

### Crest Audio® CPL™ 6

The new CPL two-way enclosure series features high power ratings with custom components, a sleek look and a unique, snap-in metal grille. The CPL6 is a two-way system featuring tweeter protection, 1" soft domed tweeter, and one maximum-performance 6.5" woofer. It is rated at 100 Watts continuous and 400 Watts peak. This lightweight speaker system is ideal for smaller venues where space is at a premium. Connections include a NL-4 four-pin twist-lock jack and a screw terminal barrier strip. The CPL Series is available in black.

#### \*Features

- Two-way sound reinforcement enclosure
- Designed for permanent installations
- Premium 6.5" woofer
- 1" soft domed tweeter
- Tweeter protection included
- Available in black
- Continuous power: 100 W  
Peak power: 400 W peak power handling
- 93 Hz-17 kHz
- 93 dB at 1W/1m
- 8 Ohms

#### Specification:

- Type: Two-way passive crossover speaker system  
Continuous power: 100W  
Peak power: 400W
- Impedance: 8 OHMS
- Sensitivity (1W@1m): 93 dB
- Maximum sound pressure level (1 meter): 113 dB @100W (119 dB @400W Peak)
- Frequency response, 1 meter on-axis, swept-sine in anechoic environment:  
93 Hz—17 kHz, -6 dB
- Nominal coverage pattern (-6 dB): 75° H×65° V
- Transducer complement: 1 x 1" (25mm VC) diaphragm  
1 x 6.5" woofer (30mm VC)
- Input connections: NL4 4-pin jack × 1 PIN 1+ = (+) POSITIVE, PIN 1- = (-) NEGATIVE  
PIN 2+ and PIN 2-, NC  
2-Position screw terminal block
- Material: 12mm (0.47") plywood
- Surface treatment: Black textured polyester paint
- Dimensions: H314mm x W 215mm x D 228mm  
H12.37" x W 8.50" x D 8.94"  
Packing size: H 395mm x W 290mm x D 300mm  
H 15.55" x W 11.42" x D 11.81"
- Net Weight: 5.0kg (12 lbs)

## Flying or Mounting the CPL Enclosure

**⚠ CAUTION:** Before attempting to suspend this speaker, consult with a certified structural engineer. Speaker can fall from improper suspension, resulting in serious injury and property damage. Do not suspend or mount any other product or device from this enclosure! Use only the correct mating hardware. All associated rigging is the responsibility of others. Maximum enclosure angle 30 degrees.

Whenever possible, in addition to the nominal primary mounting method, use a suitable safety chain or wire rope attached to one of the other groups of fly point inserts, and firmly attached to a suitable structural member as indicated by a certified structural engineer.

We recommend the use of Tread-locker at the insert point bolts, so the bolts cannot vibrate loose. Never transport the cabinet using the array bracket or other mounting brackets as a structural member, while the cabinet is mounted on an array bracket or other mounting bracket and unsupported otherwise, as this may unduly stress the mounting inserts.

This Crest Audio® loudspeaker should be suspended overhead only in accordance with the procedures and limitations specified in the User's Manual and possible manual update notices. This system should be suspended with certified rigging hardware by an authorized rigging professional and in compliance with local, provincial or national suspension ordinances.

## INSTALLATION

**⚠** Six M8 1.25 mm per thread threaded mounting suspension points (2 each top and 2 each both sides) are provided. These are plugged with a hex key beveled head bolt.

Four more M5 mounting locations are present, these are on the rear, and centered from side to side and near the bottom. These are plugged with a plastic cap.

The nineteen mounting suspension points are for use with forged shoulder machinery eyebolts and should be an M8 size, 1.25 mm per thread, and must conform to at least DIN 580 or ASTM A489, or whatever local, provincial or national suspension ordinances or regulations may additionally require. Eyebolts must be used in groups of 3 or 4, never use just one or two eyebolts to hang the speaker overhead.

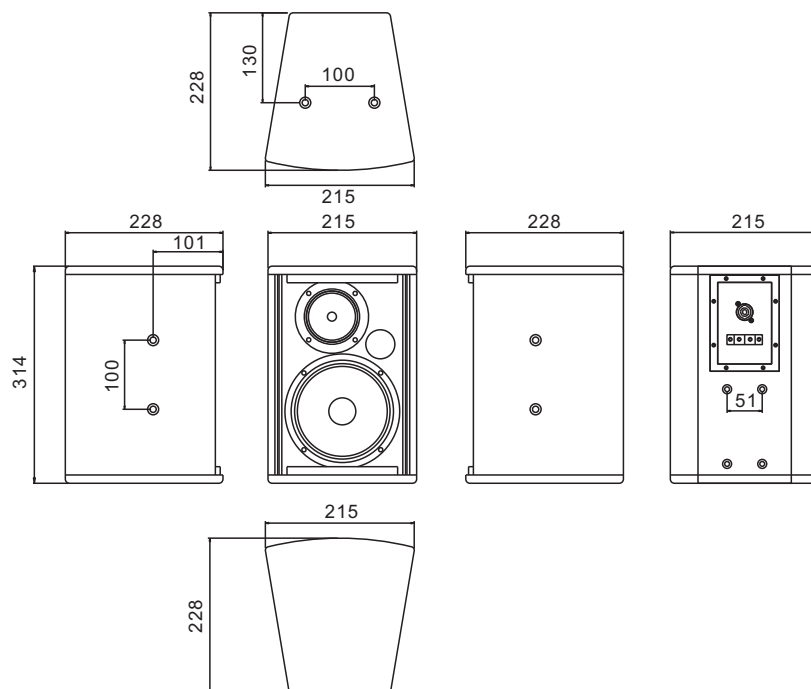

## 产品规格

### Crest Audio®CPL™6

全新的CPL两分频系列扬声器具有高的额定功率值, 定制组件, 时尚的外观和独特的嵌入式网罩。CPL6是两分频系统, 具有高音单元保护, 1"软球顶高音单元和6.5"高性能低音单元。额定连续功率为100W, 峰值功率400W。这种轻巧的扬声器系统非常适合空间有限的小型场所。连接包括NL-4四脚插座和一个2位接线端子。CPL系列为黑色。

#### \*特点

- 两分频扩声扬声器
- 固定安装
- 6.5"优质低音单元
- 1"软球顶高音单元
- 高音单元保护
- 颜色: 黑色
- 持续功率: 100W  
峰值功率: 400W
- 93Hz-17kHz
- 93dB at 1W/1m
- 8 Ohms

#### 技术参数

- 系统类型: 两分频被动式扬声器系统  
持续功率: 100W  
峰值功率: 400W
- 阻抗: 8 OHMS
- 灵敏度 (1W@1m): 93dB
- 最大声压级(1米): 113dB@100W (119dB@400W 峰值)
- 频率响应: 93Hz—17kHz, -6dB
- 覆盖角 (-6dB): 75° H×65° V
- 换能器配置: 1 x 1" 高频驱动器(25mm 音圈)  
1 x 6.5" 低频驱动器 (30mm 音圈)
- 输入连接器: N14 4-pin jack × 1 PIN 1+ = (+)正极, PIN 1- = (-)负极  
PIN 2+ and PIN 2-, 悬空  
2位接线端子
- 箱体材质: 12mm (0.47") 优质夹板
- 表面处理: 黑色水性聚酯漆
- 产品尺寸: H 314mm x W 215 mm x D 228 mm  
H 12.37" x W 8.50" x D 8.94"  
包装尺寸: H 395mm x W 290mm x D 300mm  
H 15.55" x W 11.42" x D 11.81"
- 净重: 5.0kg (12 lbs.)

## 吊挂或安装CPL系列音箱

**注意:** 在试图吊挂该扬声器之前, 请咨询有资质认证的结构工程师。 扬声器可能会因吊挂不正确而掉落, 从而会导致严重的人身伤害和财产损失。 不要在该产品箱体上吊挂或安装任何其他产品或设备! 只能使用正确配套的五金硬件。 所有相关的索具都是他人的责任。 音箱最大吊装角度为30度。

尽可能, 除了标准的主要安装方法外, 还应使用适合的安全链或钢丝绳连接到音箱其他一组吊挂点上, 并按照有资质的结构工程师的指示牢固地连接到合适的结构件上。

我们建议使用螺纹胶在插入的螺栓处, 防止螺栓松动。 在将箱体安装在阵列支架或其他安装支架上且没有其他支撑的状态下, 切勿使用阵列支架或其他安装支架作为结构部件搬运箱体。 因为这可能会对安装插入件造成过度的承受压力。

Crest Audio® 扬声器只能根据产品说明书中规定的步骤及限定的参数和可能的手册更新通知将扬声器悬挂到高于头顶位置。 该系统应由经过授权的索具专业人士使用经过认证的索具硬件进行悬挂, 并遵守地方, 省或国家的悬挂安装条例。

## 安装

该系统共提供6个1.25 mm螺纹M8尺寸安装吊挂点(顶部2个和两侧各4个) 这些装入的是六角螺栓。

4个更多的M5安装位置是存在的, 这些是在后方, 并从一边到一边的中心, 接近底部。 这些是用塑料盖塞住的。

6个安装悬挂点与锻造肩部机械吊环螺栓一起使用, 应该是M8尺寸, 每根螺纹1.25毫米, 并且必须至少符合DIN 580或ASTM A489, 或任何地方、省或国家悬挂条例或法规的要求。 吊环必须以3个或4个为一组来使用, 切勿只用1个或2个吊环螺栓把扬声器挂在头顶上。

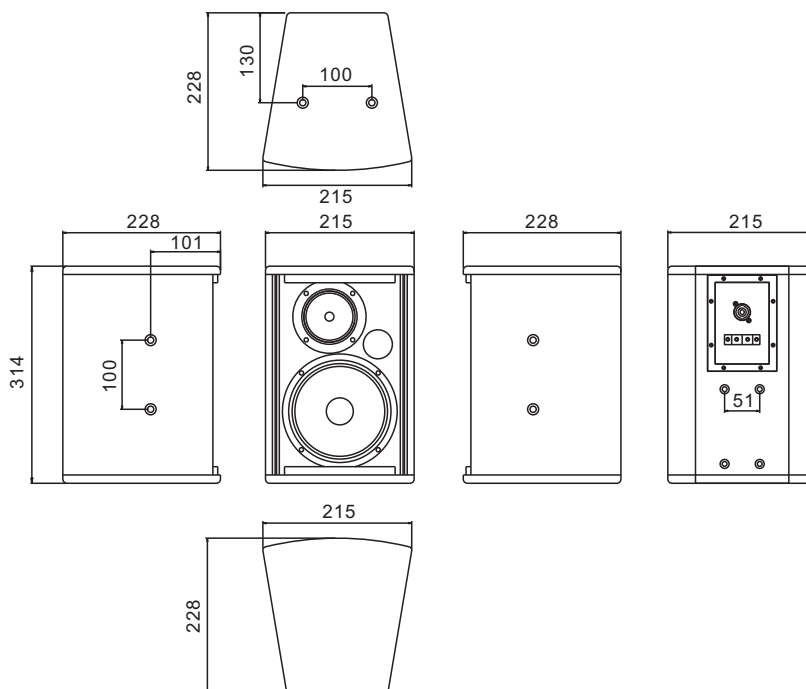







[www.peaveycommercialaudio.com](http://www.peaveycommercialaudio.com)

Warranty registration and information for U.S. customers available online at  
[www.peaveycommercialaudio.com/warranty](http://www.peaveycommercialaudio.com/warranty)  
or use the QR tag below



Features and specifications subject to change without notice.

Crest Audio 5022 HWY 493 N. Meridian, MS 39305 (601) 483-5365 FAX (601) 486-1278



Logo referenced in Directive 2002/96/EC Annex IV  
(OJ(L)37/38, 13.02.03 and defined in EN 50419: 2005  
The bar is the symbol for marking of new waste and  
is applied only to equipment manufactured after  
13 August 2005